

Signature Series

Maximum Resilience Broadcast Audio



Signature UBBU2

Stereo unbalanced to balanced & balanced to unbalanced converter

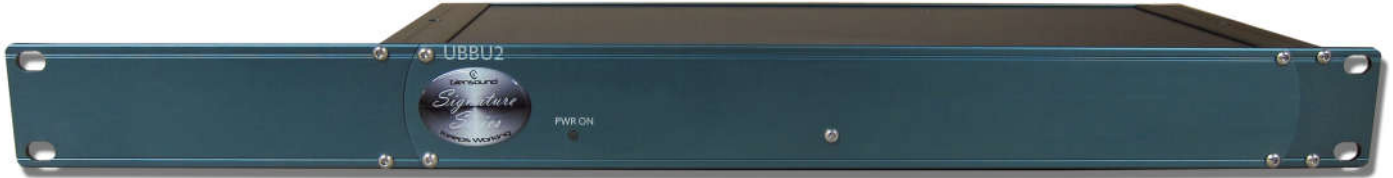

UBBU2 Front



UBBU2 Rear

FEATURES

1 x unbalanced stereo input to balanced stereo output

1 x balanced stereo input to unbalanced stereo output

Can be used as mono circuits as well as stereo

Gain controls to adjust domestic to professional levels and vice versa

The Signature UBBU2 is a broadcast specification stereo unbalanced to balanced, and balanced to unbalanced analogue audio interface that is equally suitable for professional & home studio use.

It is most commonly used for interconnecting domestic type recording / playback devices to broadcast / professional equipment.

Its primary job is to interface domestic type audio outputs (unbalanced) to the balanced audio inputs on broadcast and professional audio equipment while simultaneously connecting balanced outputs from professional equipment to the unbalanced inputs on domestic products.

As well as providing the balancing interface the UBBU2 also provides variable gain/ loss to allow the two connected pieces of equipment to match audio levels.

The two stereo circuits can both work as dual mono. Both the inputs are electronically isolated with RF filters to prevent extraneous signals, and fed via multi-turn preset gain controls on the rear panel to their outputs.

The rear panel gain controls are multi-turn presets to allow accurate gain setting and are also recessed to prevent accidental movement.

Power is provided by an internal switch mode power supply with a wide input range. There is also an input for external 12V DC power. The 12V DC input can be connected to the optional Signature PS1 external DC Master Power Station, for situations where a redundant power supply is desirable.

A bright front panel LED indicates that the unit is operational.

Signature UBBU2

Stereo unbalanced to balanced & balanced to unbalanced converter

EXAMPLE APPLICATION

CD RECORD/ PLAYBACK TO BROADCAST DESK

Interface a domestic CD player to a Broadcast desk



Many radio stations and studios incorporate mid level domestic audio equipment such as CD recorders as they provide reasonable value for money in comparison to professional versions. The output of such devices need to be correctly interfaced with a professional or broadcast audio desk.

In this example the UBBU2 will be located near the CD player as it is prudent to keep the unbalanced audio cables as short as practicable.

The UBBU2 is performing both balance conversion (in and out) and adding gain/ loss to adjust the low domestic input & output level of the CD recorder to the higher levels associated with professional mixing desks.

The inputs & outputs of the UBBU2 on the mixer side, being balanced, are more suitable for longer cable runs and therefore the CD recorder/ UBBU2 equipment can be placed much further away from the mixer than the CD recorder alone could ever be.



Signature Series

Maximum Resilience Broadcast Audio



Signature UBBU2

Stereo unbalanced to balanced & balanced to unbalanced converter

AUDIO BLOCK DIAGRAM

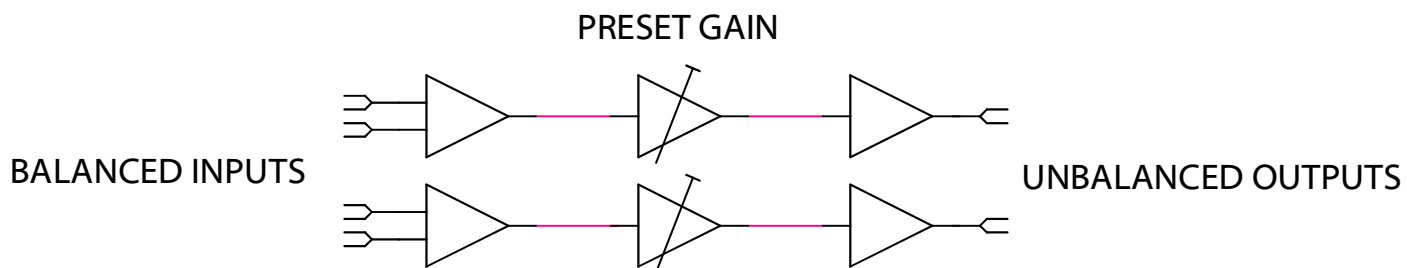
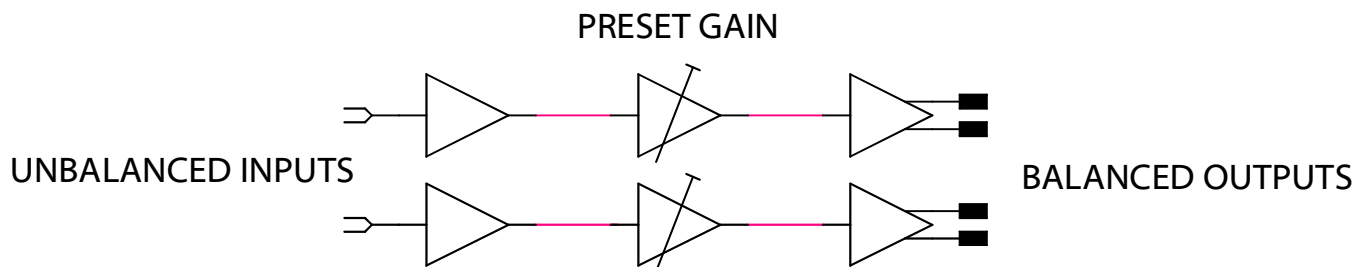
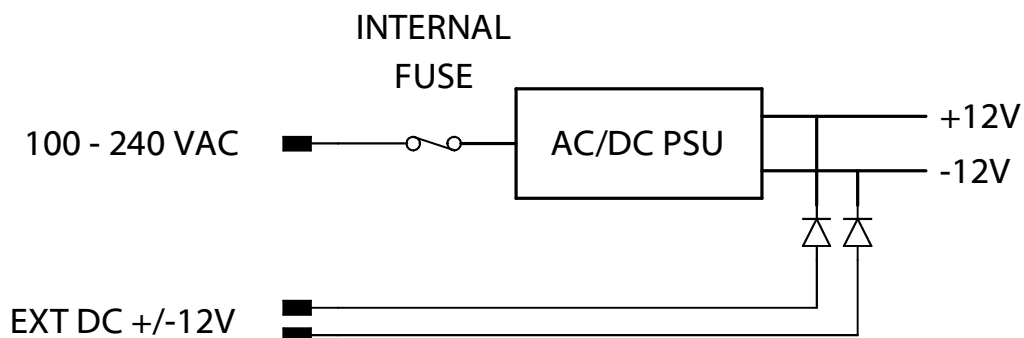

GlenSound

Keeps Working



Signature UBBU2

Stereo unbalanced to balanced & balanced to unbalanced converter

SPECIFICATION

AUDIO UNBALANCED TO BALANCED

Frequency Response @ Line Up

<+/-0.1dB 40Hz to 20kHz

Gain Range

-15dB to +15dB on each output

Line Up Level (with 0dB Gain)

-12dBu on unbalanced input = 0dBu on balanced output

Maximum Input Level

+28dBu

Maximum Output Level

+24dBu

Input Impedance

>22k Ohm

Output Impedance

<50 Ohms

Distortion

0.04% THD @ 100Hz, 1kHz & 0.01% @ 10kHz

Reference to +0dBu output

Noise

-98dB @ line up unweighted

RMS (22Hz to 22kHz) ref +8dBu output

Crosstalk

<-90dBu 1kHz to 15kHz @ lineup

AUDIO BALANCED TO UNBALANCED

Frequency Response @ Line Up

<+/-0.1dB 40Hz to 20kHz

Gain Range

-18dB to +10dB on each output

Line Up Level (with 0dB Gain)

0dBu on balanced input = -12dBu on unbalanced output

Maximum Input Level

+28dBu

Maximum Output Level

+20dBu

Input Impedance

>50k Ohm

Output Impedance

<50 Ohms

Noise

-103dB @ line up unweighted

RMS (22Hz to 22kHz) ref -4dBu output

Crosstalk

<-90dBu 1kHz to 15kHz @ lineup

POWER

Mains Input

Filtered IEC, 100 to 240VAC

47 - 63Hz

AC Consumption

1.3 Watts @ 230VAC

DC Input

4 Pin Neutrik XLR plug +/- 12V

Internal Mains Fuse

20mm 1A Anti Surge

PHYSICAL

Size

338 x 123 x 44mm (LxDxH) no rack ears

482mm 19" (1RU) with rack ears

Weight

1.00kg

Mechanics

All aluminium construction, anodized and laser etched

Shipping Carton

Rugged export quality cardboard carton

610 x 420 x 130mm LxDxH

Shipping Weight

2.3kg

INCLUDED

Mains Lead

2 Metre Long Mains Lead

(UK & Europe only)

Rack Bolts

4 off Pozzi head M6

Feet

4 off rubber stick on feet

Handbook

Full A4 handbook available to download and linked by QR code on device

ENVIRONMENTAL

Operating Temperature

0 to +50 °C (32° to 122°F)

Storage Temperature

-20 to +70 °C (-4° to 158°F)

Relative Humidity

0 to 95% non-condensing

Signature Series

Maximum Resilience Broadcast Audio



Signature Series Standard Features

STANDARD FEATURES

19" Rack Mount Ears



A Signature unit can rack mount in a 1U 19" rack, regardless of the size of the unit. Rack ears are included as standard with every unit.

Front Or Rear Mounting



A Signature unit can be rack mounted via the front panel or if it is more convenient, via the rear panel by simply swapping the rack ears over.

Side Wings For Flat Surface Fixing



A Signature unit has side wings with mounting holes at the top and bottom, allowing flush fixing from above **OR** underneath.

Neutral Colour Scheme To Complement Equipment Areas



Rack Screws Included



Modern Design



Internal Switch Mode AC Power Supply



A Signature unit has an internal switch mode AC power supply, allowing worldwide power connections from 100-240V via an IEC socket.

12V DC Power Connection



All Signature units (except PS1) have a 4 pin XLR $\pm 12V$ DC socket for connection to the PS1 Power Station. This can act as the primary or backup power source.

Quick Find Manual



A Signature unit has a QR code attached. This can be scanned to simply and quickly locate the manual and technical information.

CONTACT

Glensound
6 Brooks Place, Maidstone
Kent, UK, ME14 1HE
Tel: +44 (0)1622 753 662
Web: www.glensound.com
Email: sales@glensound.com

Glensound
Keeps Working